

RoHS

Recommended P.C.B Layout
General Tolerance±0.05

Specification:

- Current Rating: 9A AC/DC
- Voltage Rating: 600V AC/DC
- Insulation Resistance: 1000MΩ(Min)
- Contact resistance: 20mΩ(Max).
- Withstanding Voltage: 1500VAC(Min)
- Operation Temperature: -25°C to +85°C

Material:

- Insulator Material: Nylon 66(UL94V-2)
- Contact Material: Brass
- Finish: Tin Plated
- Color: Natural

Ordering Information

SCT4201WV -2xx C 0 NA 103

No.of Pins See Table
Material C=PA66 V2
Package 0=PE Bag
Color NA=Natural

2x09	33.60	39.00			
2x08	29.40	34.80			
2x07	25.20	30.60			
2x06	21.00	26.40			
2x05	16.80	22.20			
2x04	12.60	18.00			
2x03	8.40	13.80	2x12	46.20	51.60
2x02	4.20	9.60	2x11	42.00	47.40
2x01	—	5.40	2x10	37.80	43.20
Poles	A	B	Poles	A	B
	Dimensions			Dimensions	

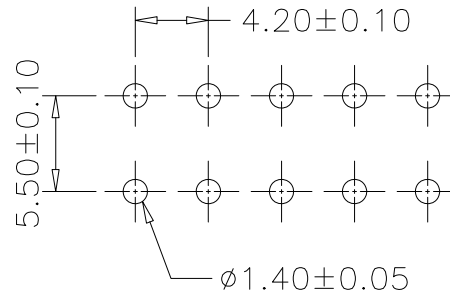
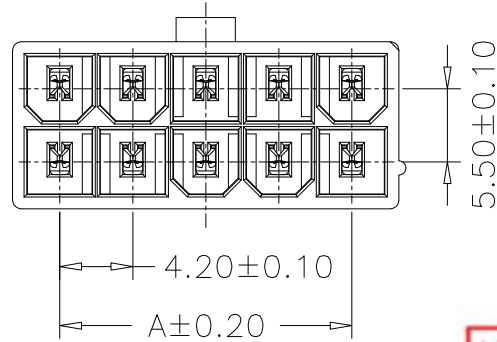

东莞市视凯达电子科技有限公司
工程专用章

受控

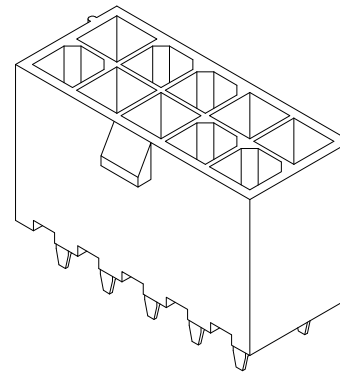
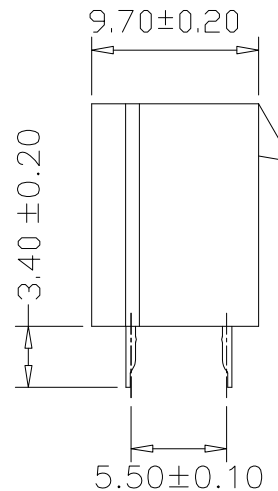
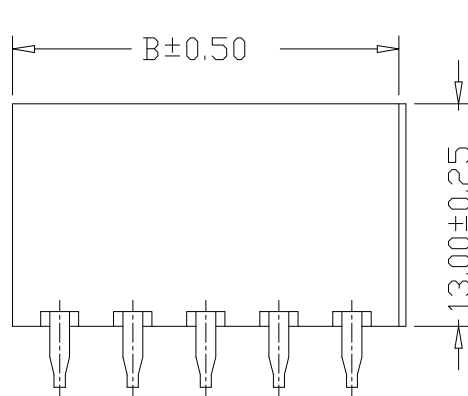

REV	DATE	MODIFICATION DESCRIPTION	CHANGE	APPROVE	OPERATION	DRAW	Peng	2021.07.10	SCALE	—	 SCONDAR ELECTRONIC LIMITED
A1	2021.07.10	Changed from SCT4201WV-2xxP to SCT4201WV-2xxC0NA103	—	—	X.X	±0.35			UNIT	mm	
AO	2020.03.03	NEW	—	—	X.XX	±0.25			SIZE	A4	
					X.XXX	±0.15			SHEET	1/1	
					Angle	± 3'			PART NO.	SCT4201WV-2xxC0NA103	
					DIM	TOL	APPROVE	Allen	2021.07.10	PROJ.	 TITLE: MX4.2 180° Wafer