

SPECIFICATIONS

Voltage Rating: 50V AC/DC

Current Rating: 0.5A AC/DC

Withstanding Voltage: 500V AC/minute

Insulation Resistance: 500MΩ min.

Temperature Range: -25° C - +85° C

Contact Resistance: 30mΩ max

MATERIAL

1. Housing: PA46/LCP UL94V-0

2. Locker: PPS, UL94V-0

3. Contact: Phosphor bronze, Tin plated

4. Solder tab: Phosphor bronze, Tin plated

Pin	Type	A	B	C
8	50D-8PLB	3.5	4.56	7
10	50D-10PLB	4.5	5.56	8
14	50D-14PLB	6.5	7.56	10
16	50D-16PLB	7.5	8.56	11
20	50D-20PLB	9.5	10.56	13
22	50D-22PLB	10.5	11.56	14
24	50D-24PLB	11.5	12.56	15
25	50D-25PLB	12	13.06	15.5
26	50D-26PLB	12.5	13.56	16

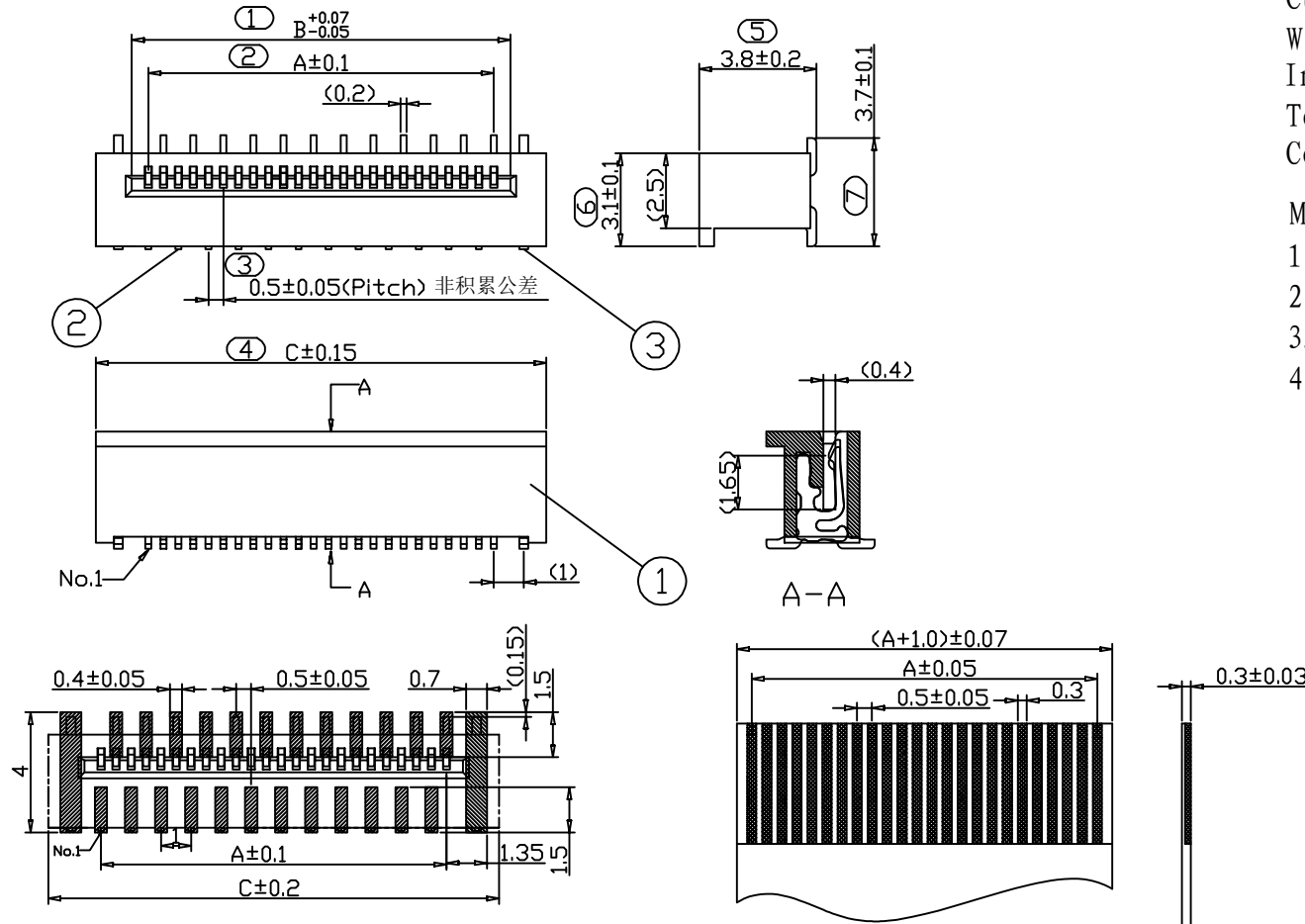
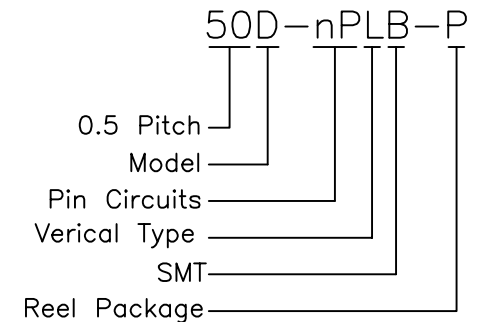

APPLICABLE_FPC

REV	DATE	MODIFICATION DESCRIPTION	CHANGE	APPROVE	OPERATION	DRAW	YANG	2016.07.20	SCALE	UNIT	mm	PART NO.	50D-nPLB
0	05/12/27	NEW			~ 10	DESIGN							
					20 ~ 30	CHECK	MICKY	2016.07.20				TITLE:	0.5mm Pitch "D" Verical SMT FPC
					30 ~	APPROVE	ALLEN	2016.07.20				DRAWING NO.	50D-nPLB

SCONDAR 森康达电子有限公司
SCONDAR ELECTRONIC LIMITED