

A
B
C
D
E
F
G

A
B
C
D
E
F
G

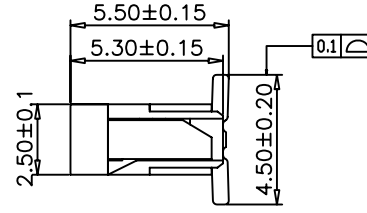
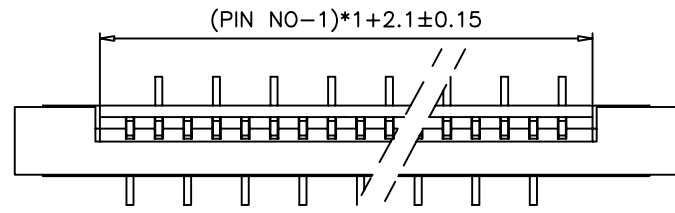

SPECIFICATIONS

Voltage Rating: 50V AC/DC
 Current Rating: 0.5A AC/DC
 Withstanding Voltage: 500V AC/minute
 Insulation Resistance: 500MΩ min.
 Temperature Range: -25° C - +85° C
 Contact Resistance: 30mΩ max
 Poles: 4-60

MATERIAL

1. Housing: Nylon46 UL94V-0
2. Locker: PPS, UL94V-0
3. Contact: Phosphor bronze, Tin plated
4. Solder tab: Phosphor bronze, Tin plated

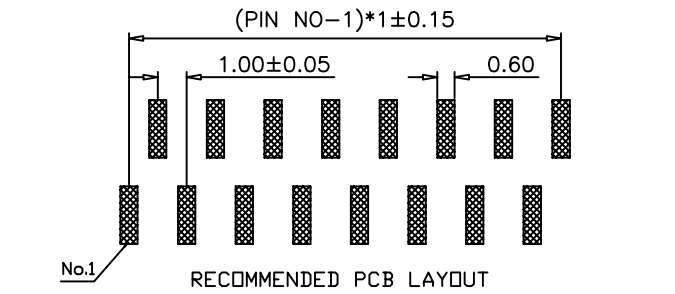
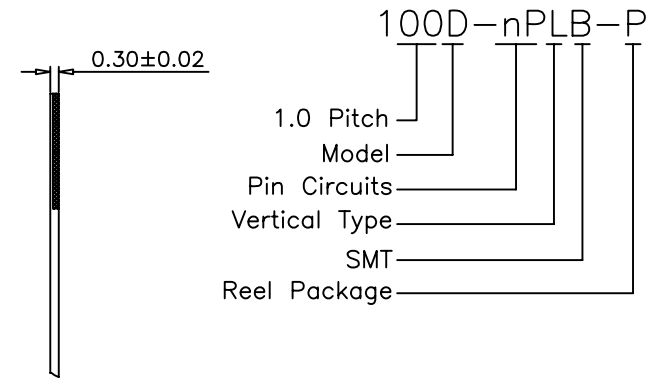
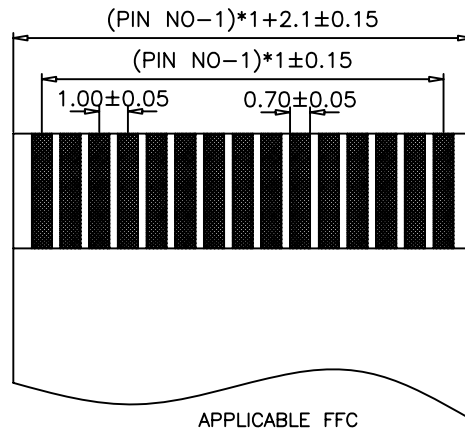
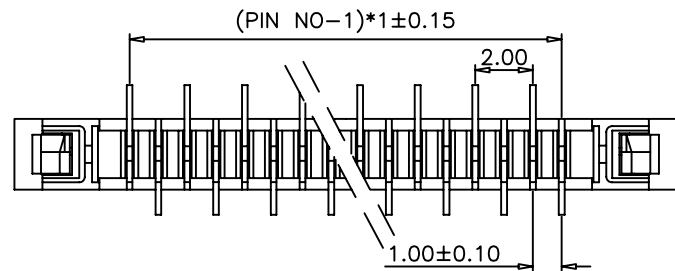
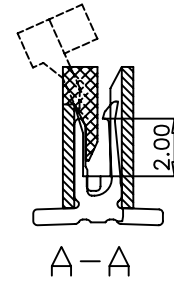
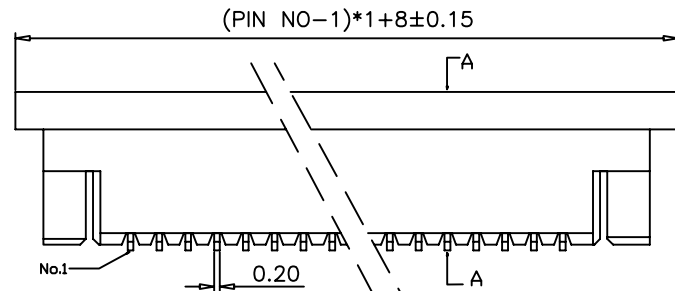

| | | | | | | | | | | | | | |
|-----|----------|--|--------------------------|--------|---------|---------------|---------|--------|----------|-------|-----|---|--------------------------------------|
| | | | | | | OPERATION | DRAW | CHENA | 14/09/18 | SCALE | | 森康达电子有限公司 SCONDAR ELECTRONIC LIMITED | |
| | | | | | | ~ 10 ±0.15 | DESIGN | | | UNIT | mm | | |
| | | | | | | 20 ~ 30 ±0.30 | CHECK | Micky | 14/09/18 | SIZE | A4 | PART NO. | 100D-nPLB |
| | | | | | | 30 ~ ±0.50 | APPROVE | HELLEN | 14/09/18 | SHEET | 1/1 | TITLE: | 1.0mm Pitch "D"Vertical Type SMT FPC |
| 0 | 05/12/27 | | NEW | | | Angle ± 2' | APPROVE | | | PROJ. | ◆ | DRAWING NO. | 100D-nPLB |
| REV | DATE | | MODIFICATION DESCRIPTION | CHANGE | APPROVE | DIM TOL | | | | | | | |