

A
B
C
D
E
F
G
H

A
B
C
D
E
F
G
H

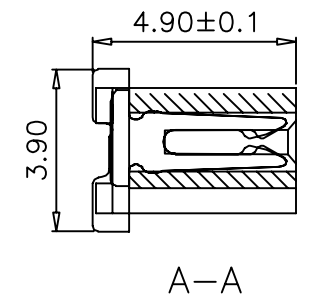

SPECIFICATIONS
 Voltage Rating: 50V AC/DC
 Current Rating: 0.5A AC/DC
 Withstanding Voltage: 500V AC/minute
 Insulation Resistance: 500MΩ min.
 Temperature Range: -25° C - +85° C
 Contact Resistance: 30mΩ max
 Poles: 4-60

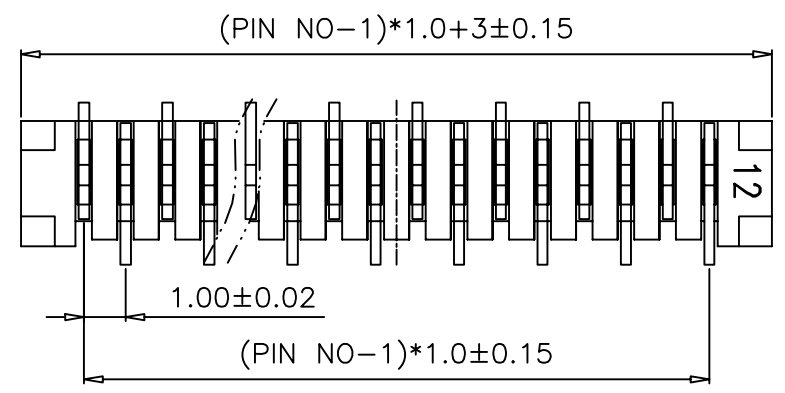
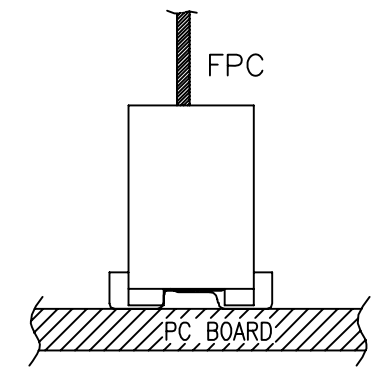
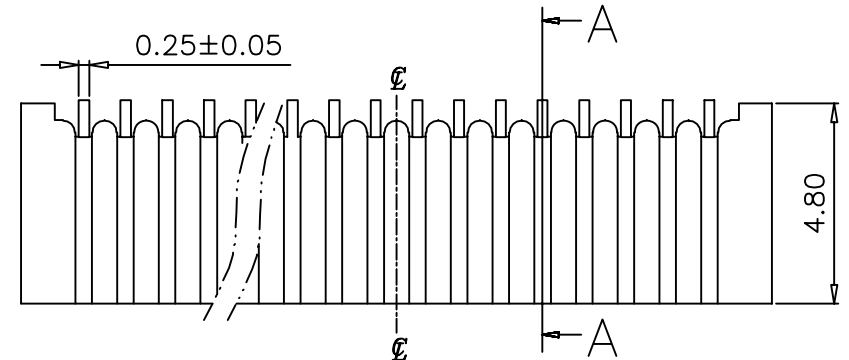

MATERIAL
 1. Housing: Nylon46 UL94V-0
 2. Locker: PPS, UL94V-0
 3. Contact: Phosphor bronze, Tin plated
 4. Solder tab: Phosphor bronze, Tin plated

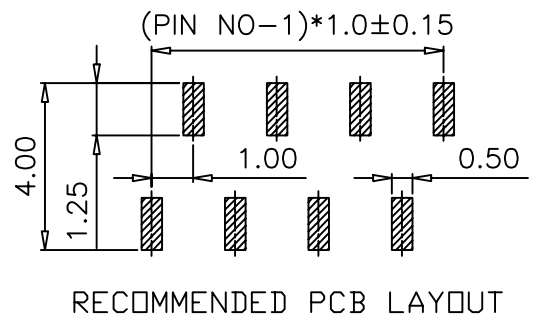
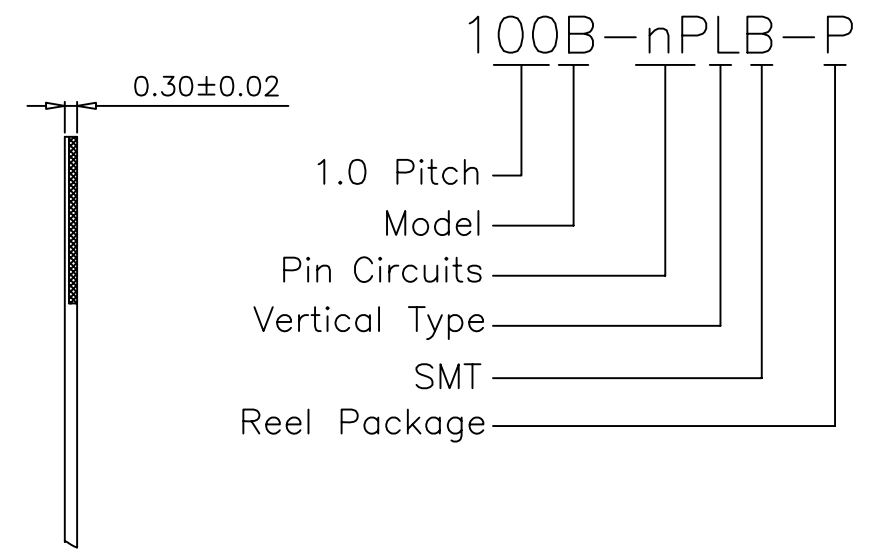
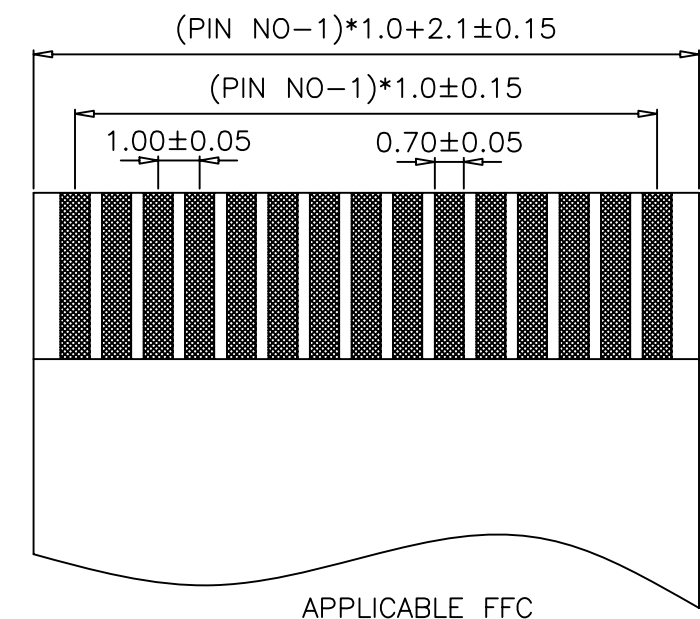
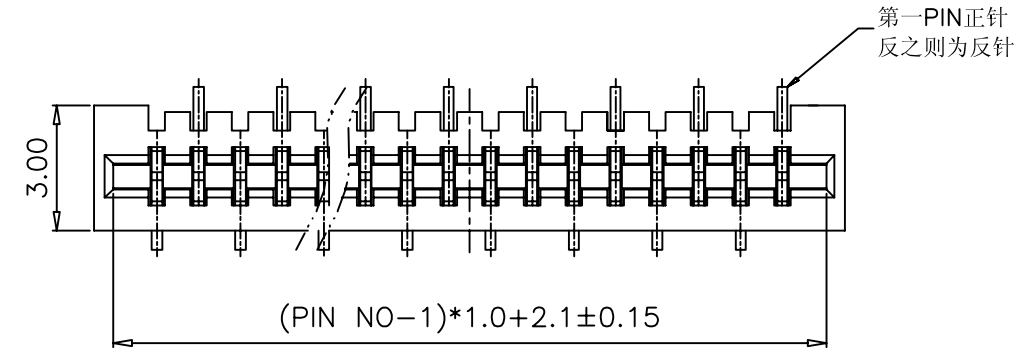

					OPERATION	DRAW	CHENA	14/09/18	SCALE	森康达电子有限公司 SCONDAR ELECTRONIC LIMITED		
					~ 10 ±0.15	DESIGN			UNIT			mm
					20 ~ 30 ±0.30	CHECK	Micky	14/09/18	SIZE	A4	PART NO.	100B-nPLB
0	05/12/27		NEW		30 ~ ±0.50	APPROVE	HELLEN	14/09/18	SHEET	1/1	TITLE:	1.0mm Pitch "B" Vertical Type SMT FPC
REV	DATE		MODIFICATION DESCRIPTION	CHANGE	APPROVE				PROJ.	⊕	DRAWING NO.	100B-nPWB