



Product Specification :	ISSUED BY: Engineering Dept	
Subject : 1.25mm Pitch SCT1254 Series Connector Specification	Date Issued	2014/02/01
	Date Revised	2014/08/08

This specification is referred to the 1.25mm series wire to board connector

INDEX

1. Scope
2. Spec and Part number
3. Disposal of Material and surface
4. Ratings and applicable wires
5. Performance
 - 5-1. Electrical Performance.
 - 5-2. Mechanical Performance
 - 5-3. Environmental Performance and Others
6. Insertion/Withdrawal Force
7. SMT Infrared Reflow Condition



Product Specification:	ISSUED BY: Engineering Dept	
Subject : 1.25mm Pitch SCT1254 Series Connector Specification	Date Issued	2014/02/01
	Date Revised	2014/08/08

1. Scope

This Specification Covers the 1.25mm Pitch SCT1254 Series Connector Specification.

2. Spec and Part number

Specification	Production No.	Picture of Product
Terminal	SCT1254T	NONE
Housing	SCT1254H-XXP	NONE
Wafer	SCT1254WR-S-XXP	NONE

3. Disposal of Material and surface

Specification	Materials	Disposal of Surface
Terminal	Phosphor Bronze	Nickel: Over 30μ" Min. Gold Flash or 1μ" or 3μ"
Housing	PA66	UL 94V-0
Wafer	Base	High Temperature Plastic
	PIN	Phosphor Bronze
	Solder tab	Phosphor Bronze
		UL 94V-0
		Gold Plated Over 30μ" Nickel
		Gold Plated Over 30μ" Nickel

(Please Refer to the Project drawing for the above Specification)

4. Ratings and applicable wires

Item	Standard	
Rated Voltage (Max.)	125V	[AC/DC]
Rated Current (Max.)	1.0A	
Ambient temperature Range	-40°C~+85°C	
Applicable wire insulation O.D	AWG 28#~32# Insulation O.D. 0.90mm(Max.)	

*Including terminal temperature rise.

Product Specification :	ISSUED BY: Engineering Dept	
Subject : 1.25mm Pitch SCT1254 Series Connector Specification	Date Issued	2014/02/01
	Date Revised	2014/08/08

5. PERFORMANCE

5-1. Electrical Performance.

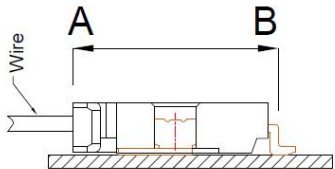
Item	Test Condition	Requirement
5-1-1 Contact Resistance	Mate connectors, measure by dry circuit, 20mV MAX, 10mA. (Based upon EIA-364-06A). 	Initial: 20 milliohms Max. After Test: 40 milliohms Max.
5-1-2 Insulation Resistance	Mate connectors, apply 500V DC between adjacent terminal or ground. (Based upon EIA-364-21B/MIL-STD-202 Method 302 Cond.B)	100 Megohms Min.
5-1-3 Dielectric Strength	Mate connectors, apply 250V AC for 1 minute between adjacent terminal or ground. (Based upon EIA-364-20A/MIL-STD-202 Method 301)	No Breakdown and Flashover
5-1-4 Contact resistance on crimped portion	Crimp the applicable wire on to the terminal measure by dry circuit 20mV MAX, 10mA.	10 milliohms Max.

5-1. Electrical Performance

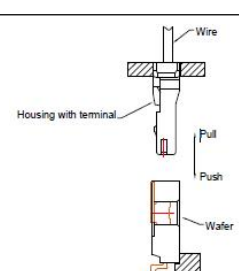
Item	Test Condition	Requirement
5-2-1 Insertion & Retention Force	Insert and withdraw Connectors at the speed rate of 25.4±3mm/minute. 	Refer to paragraph 6

Product Specification:	ISSUED BY: Engineering Dept	
Subject: 1.25mm Pitch SCT1254Series Connector Specification	Date Issued	2014/02/01
	Date Revised	2014/08/08

5-2. Mechanical Performance.

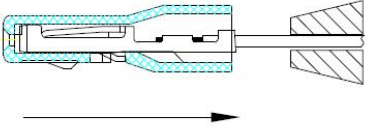
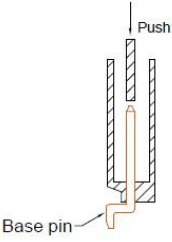
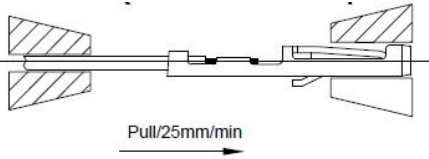
Item		Test Condition	Requirement			
5-2-2	Terminal /Housing Retention Force	Apply axial pull out force at the rate of 25.4±3mm/minute terminal assembled in the housing.	4.9N {0.5kgf} Min.			
						
5-2-3	Terminal Insertion Force	Insert the crimped terminal into the housing.	4.9N {0.5kgf} Max.			
5-2-4	Pin Retention Force	Apply axial push force at the speed of 25.4±3mm/minute.	1.96N {0.20kgf} Min.			
						
5-2-5	Tensile strength (Crimped connections)	Fix the crimped terminal, apply axial pull out force on the wire. (Do not crimp insulation part).	AWG#	#28	#30	#32
			Spec.kgf. Min.	1.0	0.5	0.3
			Note> As for unspecified wire sizes in this specification define values with clients			

5-3. Environmental Performance and Others.

Item		Test Condition	Requirement	
5-3-1	Repeated Insertion/ Withdrawal	When mated up to 50 cycles repeatedly by the rate of 10 cycles per minute.	Contact Resistance	40 milliohms Max.



Product Specification:	ISSUED BY: Engineering Dept	
Subject: 1.25mm Pitch SCT1254 Series Connector Specification	Date Issued	2014/02/01
	Date Revised	2014/08/08

Item		Test Condition	Requirement	
5-3-2	Temperature Rise	Carrying rated current load. (UL 1977)	Temperature rise	30°C Max.
5-3-3	Vibration	Amplitude: 1.5mm P-P Sweep time: 10~55~10 HZ in 1 minute Duration: 2 hours in each X.Y.Z axials. (Based upon EIA-364-28B/MIL-STD-202 Method 213B Cond.A)	Appearance	No Damage
			Contact Resistance	40 milliohms Max.
			Discontinuity	1 micro-second Max.
5-3-4	Shock	490m/s ² {50G}, 3 strokes in each X.Y.Z. axes. (Based upon EIA-364-27B/MIL-STD-202 Method 213B Cond.A)	Appearance	No Damage
			Contact Resistance	40 milliohms Max.
			Discontinuity	1 micro-second Max.
5-3-5	Heat Resistance	85±2°C,96 hours. (Based upon MIL-STD-202 Method 108A Cond.A)	Appearance	No Damage
			Contact Resistanc	40milliohms Max.
5-3-6	Cold Resistance	-25±5°C,96 hours. (Based upon EIA-364-105)	Appearance	No Damage
			Contact Resistanc	40milliohms Max.
5-3-7	Humidity	Temperature: 40±2°C Relative Humidity: 90~95% Duration: 96 hours (Based upon EIA-364-31A/MIL-STD-202 Method 103B Cond.B)	Appearance	No Damage
			Contact Resistance	40milliohms Max.
			Dielectric Strength	Must meet 5-1-3
			Insulation Resistance	100Megohms Min.
5-3-8	Temperature Cycling	5 cycles of:a) -55°C 30 minutes. b) +85°C 30 minutes. (Based upon EIA-364-32B)	Appearance	No Damage
			Contact Resistance	40milliohms Max.



Product Specification:	ISSUED BY: Engineering Dept	
Subject: 1.25mm Pitch SCT1254 Series Connector Specification	Date Issued	2014/02/01
	Date Revised	2014/08/08

Item		Test Condition	Requirement	
5-3-9	Salt Spray	24±1 hours exposure to a salt spray from the 5±1% solution at 35±2°C. (Based upon EIA-364-26A/MIL-STD-202 Method 101D Cond.B).	Appearance	No Damage
			Contact Resistance	40milliohms Max.
5-3-10	Solder-ability	Soldering Time: 5±0.5second. Solder Temperature: 245±5°C. (Based upon EIA-364-52)	Solder Wetting	95% of immersed area must show no voids, pin holes.
5-3-11	Solder-Resistance	Soldering time:5~10 sec solder. Temperature:260+5/-5°C. (Based upon EIA-364-56A)	Appearance	No Damage

6. INSERTION/WITHDRAWAL FORCE <Connector mating force>

Note:Insertion and Withdrawal for 30Cycles

No. of CKT	First Insertion (kgf Max.)	30 th Withdrawal (kgf Min.)	No. of CKT	First Insertion (kgf Max.)	30 th Withdrawal (kgf Min.)
02	0.45	0.05	10	2.20	0.20
03	0.65	0.06	11	2.40	0.22
04	0.90	0.08	12	2.65	0.24
05	1.10	0.10	13	2.85	0.26
06	1.30	0.12	14	3.10	0.28
07	1.55	0.14	15	3.30	0.30
08	1.75	0.16	20	4.40	0.40
09	2.00	0.18	30	6.60	0.60

Product Specification:	ISSUED BY: Engineering Dept	
Subject: 1.25mm Pitch SCT1254 Series Connector Specification	Date Issued	2014/02/01
	Date Revised	2014/08/08

7. SMT SMT INFRARED REFLOW CONDITION

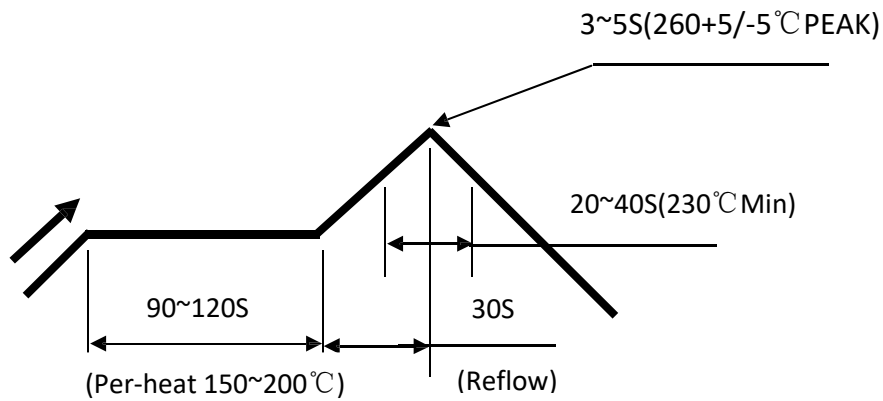

TEMPERATURE CONDITION GRAPH/ (TEMPERATURE ON BOARD PATTERNSIDE)

Notes: Please check the reflow soldering condition by your own devices beforehand. Because the condition changes by the soldering devices, P.C. boards, and so on.