

1 2 3 4 5 6 7 8 9 10

A

A

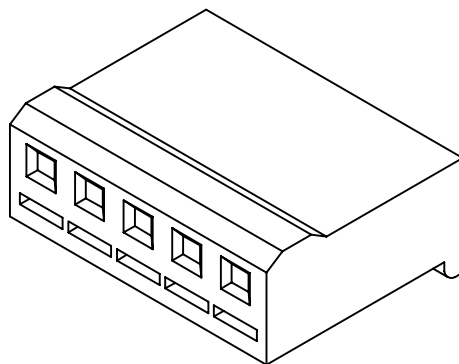
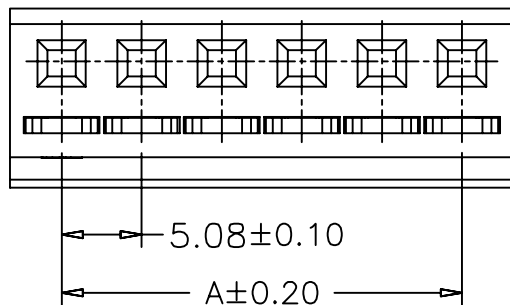

SPECIFICATIONS

Voltage Rating: 250V AC/DC
 Current Rating: 7A AC/DC
 Withstanding Voltage: 1500V AC/minute
 Insulation Resistance: 1000MΩ min.
 Temperature Range: -25° C - +85° C
 Contact Resistance: 20mΩ max

HOUSING

Part No: SCT5082H-XXP
 Pole: 02-12
 Material: Nylon 66, UL94V-2

D

D

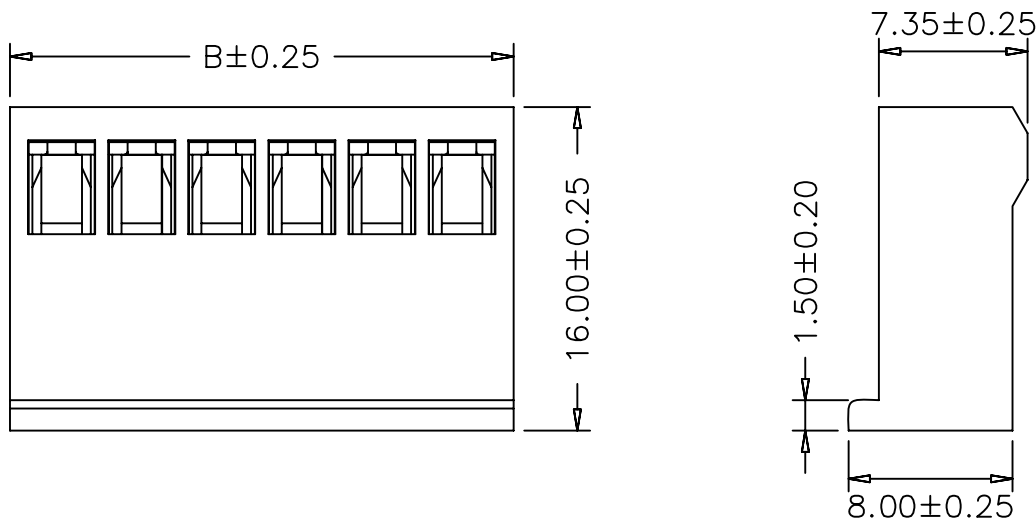

PART NO.	Dimensions	
	A	B
SCT5082H-02P	5.08	10.68
SCT5082H-03P	10.16	15.76
SCT5082H-04P	15.24	20.84
SCT5082H-05P	20.32	25.92
SCT5082H-06P	25.40	31.00
SCT5082H-07P	30.48	36.08
SCT5082H-08P	35.56	41.16
SCT5082H-09P	40.64	46.24
SCT5082H-10P	45.72	51.32
SCT5082H-11P	50.80	56.40
SCT5082H-12P	55.88	61.48

G

G

					OPERATION	DRAW	CHENA	2005.03.13	SCALE		森康达电子有限公司 SCONDAR ELECTRONIC LIMITED	
					~ 10 ±0.15	DESIGN			UNIT	mm		
					20 ~ 30 ±0.30	CHECK	MICKY	2005.03.13	SIZE	A4	PART NO.	SCT5082H-XXP
0	05/12/27				30 ~ ±0.50	APPROVE	HELLEN	2005.03.13	SHEET	1/1	TITLE:	5.08 HOUSING
REV	DATE	MODIFICATION DESCRIPTION	CHANGE	APPROVE	Angle ± 2° DIM TOL	APPROVE	HELLEN	2005.03.13	PROJ.	◆	DRAWING NO.	SCT5082

1 2 3 4 5 6 7 8 9 10

H

H