

1 2 3 4 5 6 7 8 9 10

A
B
C
D
E
F
G

A
B
C
D
E
F
G

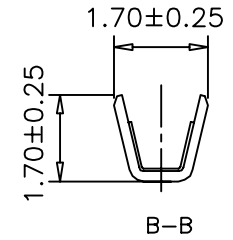
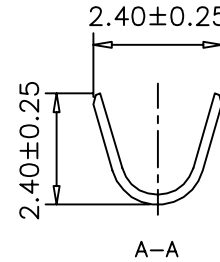
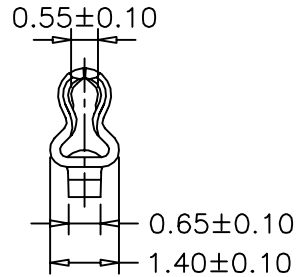
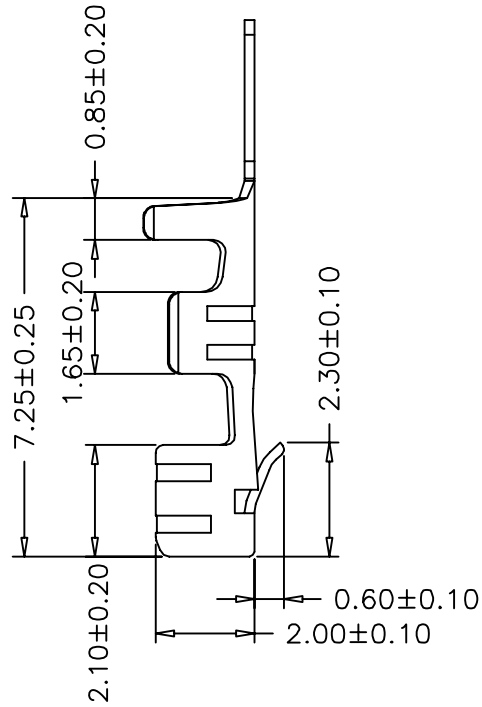
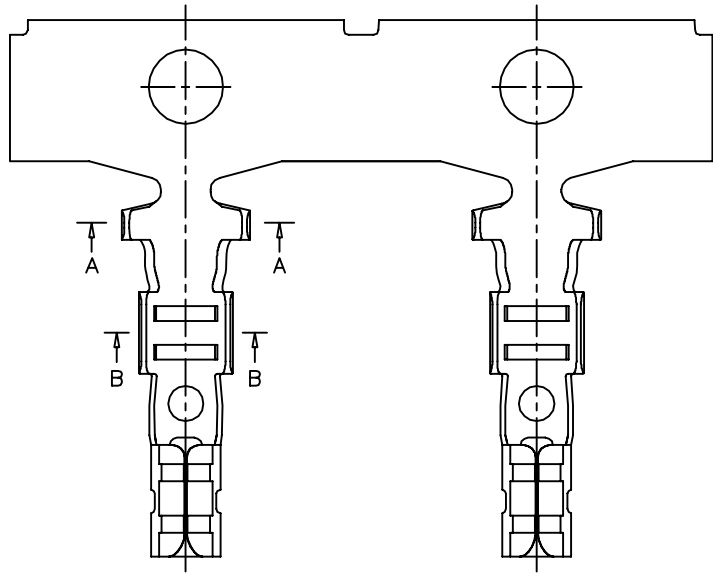

SPECIFICATIONS

Voltage Rating: 250V AC/DC
 Current Rating: 3A AC/DC
 Withstanding Voltage: 1000V AC/minute
 Insulation Resistance: 1,000MΩ min.
 Temperature Range: -25° C - +85° C
 Contact Resistance: 20mΩ max

TERMINAL

Part No: SCT2513TP
 Wire Range: AWG#22-#28 (OD1.9mm)
 Material: Phos. Bronze
 Finish: Tin Plated
 Thickness: 0.2mm
 Q`TY: 10,000PCS/Reel

						OPERATION	DRAW	CHENA	2010.12.03	SCALE		 森康达电子有限公司 SCONDAR ELECTRONIC LIMITED	
						~ 10 ±0.15	DESIGN			UNIT	mm		
						20 ~ 30 ±0.30	CHECK	MICKY	2010.12.03	SIZE	A4	PART NO.	SCT2513TP
0	05/12/27					30 ~ ±0.50	APPROVE	HELLEN	2010.12.03	SHEET	1/1	TITLE:	MOLEX2.5 Terminal
REV	DATE	MODIFICATION DESCRIPTION	CHANGE	APPROVE		Angle ± 2° DIM TOL				PROJ.	◆	DRAWING NO.	SCT2513

1 2 3 4 5 6 7 8 9 10