

1 2 3 4 5 6 7 8 9 10

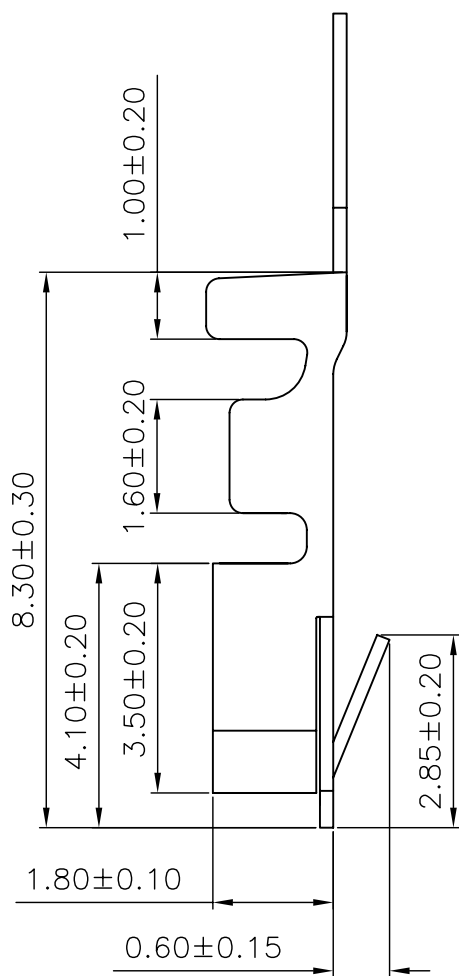
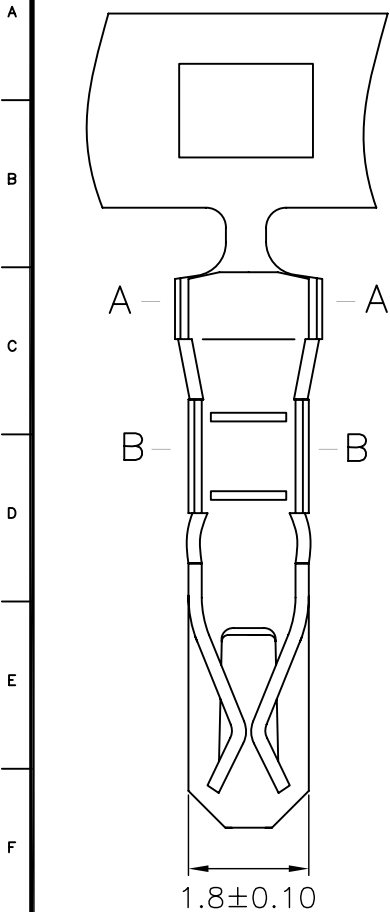

SPECIFICATIONS

Voltage Rating: 250V AC/DC
 Current Rating: 2A AC/DC
 Withstanding Voltage: 500V AC/minute
 Insulation Resistance: 800MΩ min.
 Temperature Range: -25° C - +85° C
 Contact Resistance: 20mΩ max

TERMINAL

Part No: SCT2509FT
 Wire Range: AWG#22-#28 (OD1.8mm)
 Material: Brass
 Finish: Tin Plated
 Thickness: 0.2mm
 Q`TY: 8,000PCS/Reel

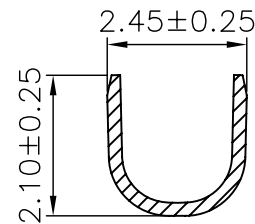

A-A

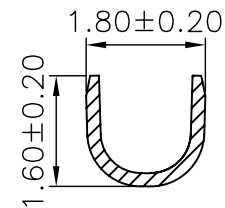

B-B

						OPERATION	DRAW	Judy.Huang	2006/05/02	SCALE		 森康达电子有限公司 SCONDAR ELECTRONIC LIMITED	
						~ 10 ±0.15	DESIGN			UNIT	mm		
						20 ~ 30 ±0.30	CHECK	Micky.Liu	2006/05/02	SIZE	A4	PART NO.	SCT2509FT
0	05/12/27		NEW			30 ~ ±0.50	APPROVE	Hellen.Li	2006/05/02	SHEET	1/1	TITLE:	SMH250 FEMALE TERMINAL
REV	DATE		MODIFICATION DESCRIPTION	CHANGE	APPROVE	Angle ± 2° DIM TOL	APPROVE			PROJ.	◆ ⇐	DRAWING NO.	SCT2509

1 2 3 4 5 6 7 8 9 10