

1 2 3 4 5 6 7 8 9 10

A

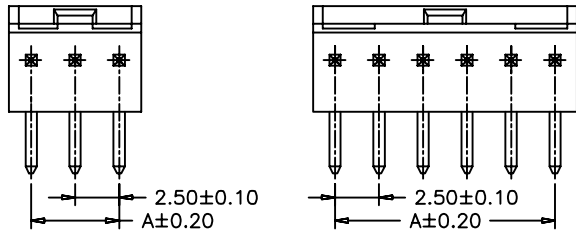

B

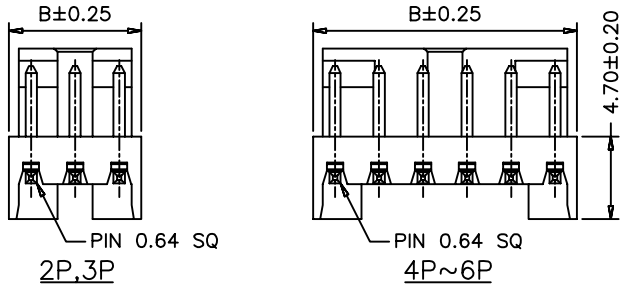

C

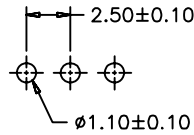
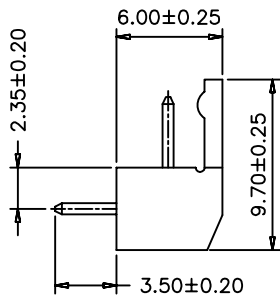

P.C.B LAYOUT

**SPECIFICATIONS**  
 Voltage Rating: 250V AC/DC  
 Current Rating: 3A AC/DC  
 Withstanding Voltage: 1000V AC/minute  
 Insulation Resistance: 1,000MΩ min.  
 Temperature Range: -25° C - +85° C  
 Contact Resistance: 20mΩ max

**HOUSING**  
 Part No: SCT2504WR-XXP  
 Poles: 2-15  
 Material: Nylon 66, UL94V-0  
 Pin: Brass, Tin plated

D

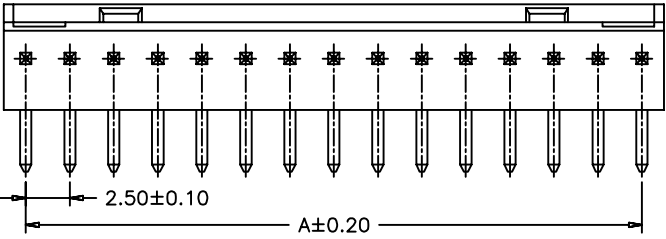

E

F

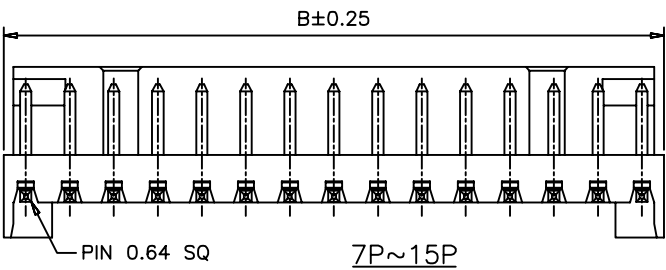

G

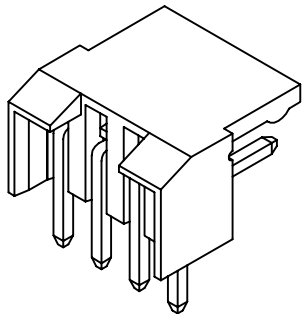
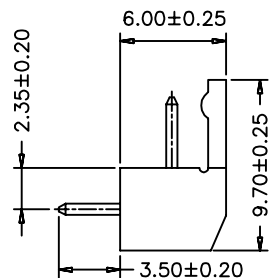

PART NO.	Dimensions	
	A	B
SCT2504WR-2P	2.50	5.00
SCT2504WR-3P	5.00	7.50
SCT2504WR-4P	7.50	10.00
SCT2504WR-5P	10.00	12.50
SCT2504WR-6P	12.50	15.00
SCT2504WR-7P	15.00	17.50
SCT2504WR-8P	17.50	20.00
SCT2504WR-9P	20.00	22.50
SCT2504WR-10P	22.50	25.00
SCT2504WR-11P	25.00	27.50
SCT2504WR-12P	27.50	30.00
SCT2504WR-13P	30.00	32.50
SCT2504WR-14P	32.50	35.00
SCT2504WR-15P	35.00	37.50

H

REV	DATE	MODIFICATION DESCRIPTION	CHANGE	APPROVE	OPERATION	DRAW	CHENA	2010.12.03	SCALE	UNIT	mm	PART NO.	TITLE:
0	05/12/27	NEW			~ 10	DESIGN						SCT2504WR-XXP	JAE2.5 90C WAFER
					20 ~ 30	CHECK	MICKY	2010.12.03					
					30 ~	APPROVE	HELLEN	2010.12.03					
					Angle ± 2°								
					DIM TOL								

**SCONDAR** 森康达电子有限公司  
 SCONDAR ELECTRONIC LIMITED

1 2 3 4 5 6 7 8 9 10