

1 2 3 4 5 6 7 8 9 10

A
B
C
D
E
F
G

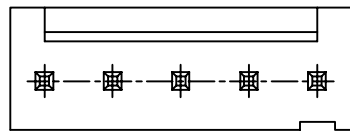

02~05P

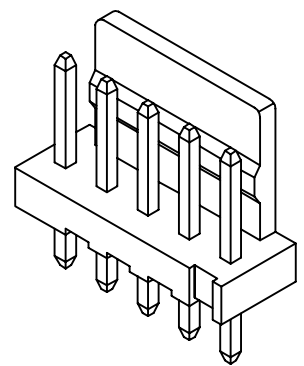

SPECIFICATIONS

Voltage Rating: 250V AC/DC
 Current Rating: 3A AC/DC
 Withstanding Voltage: 800V AC/minute
 Insulation Resistance: 1000MΩ min.
 Temperature Range: -25° C - +85° C
 Contact Resistance: 20mΩ max

WAFER

Part No: SCT2503WV-XXP
 Poles: 2-20
 Material: Nylon 66, UL94V-2
 Pin: Brass, Tin plated

PART NO.	Dimensions	
	A	B
SCT2503WV-02P	2.50	5.00
SCT2503WV-03P	5.00	7.50
SCT2503WV-04P	7.50	10.00
SCT2503WV-05P	10.00	12.50
SCT2503WV-06P	12.50	15.00
SCT2503WV-07P	15.00	17.50
SCT2503WV-08P	17.50	20.00
SCT2503WV-09P	20.00	22.50
SCT2503WV-10P	22.50	25.00
SCT2503WV-11P	25.00	27.50
SCT2503WV-12P	27.50	30.00
SCT2503WV-13P	30.00	32.50
SCT2503WV-14P	32.50	35.00
SCT2503WV-15P	35.00	37.50
SCT2503WV-16P	37.50	40.00
SCT2503WV-17P	40.00	42.50
SCT2503WV-18P	42.50	45.00
SCT2503WV-19P	45.00	47.50
SCT2503WV-20P	47.50	50.00

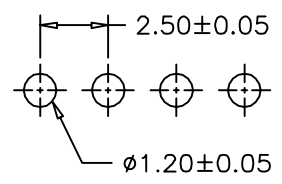
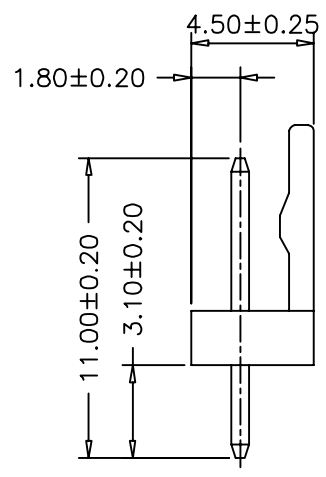
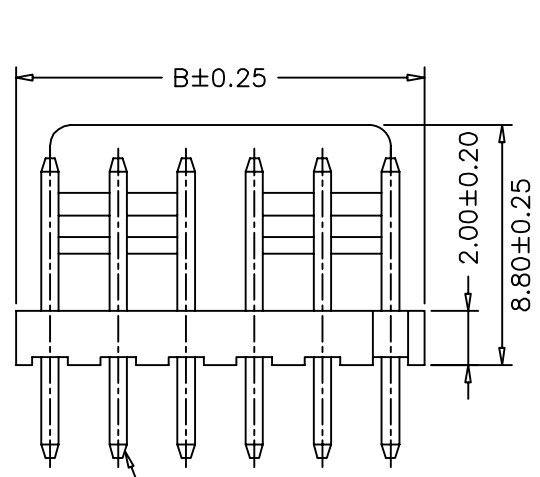
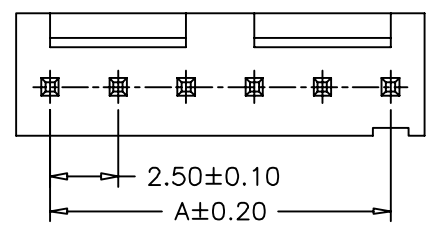

P.C.B LAYOUT

					OPERATION	DRAW	CHENA	05/12/27	SCALE		森康达电子有限公司 SCONDAR ELECTRONIC LIMITED	
					~ 10 ±0.15	DESIGN			UNIT	mm		
					20 ~ 30 ±0.30	CHECK	MICKY	05/12/28	SIZE	A4	PART NO.	SCT2503WV-XXP
					30 ~ ±0.50	APPROVE	HELLEN	05/12/28	SHEET	1/1	TITLE:	Dupont 2.5 180C WAFER
REV	DATE	MODIFICATION DESCRIPTION		CHANGE	APPROVE				PROJ.	◆	DRAWING NO.	SCT2503

1 2 3 4 5 6 7 8 9 10

A
B
C
D
E
F
G
H