

1 2 3 4 5 6 7 8 9 10

A
B
C
D
E
F
G

A
B
C
D
E
F
G

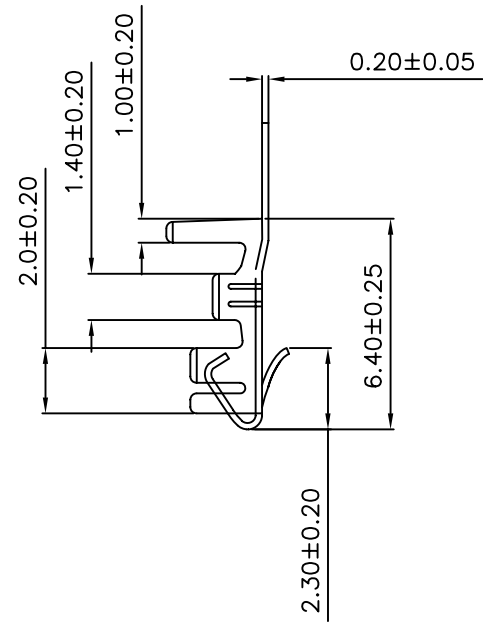

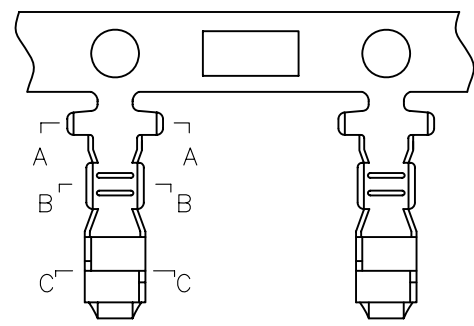

SPECIFICATIONS

- . Voltage Rating: 250V AC/DC
- . Current Rating: 3A AC/DC
- . Withstanding Voltage: 1,000V AC/minute
- . Insulation Resistance: 1,000M Ω min
- . Temperature Range: -25° C to +85° C
- . Contact Resistance: 20m Ω max

TERMINAL

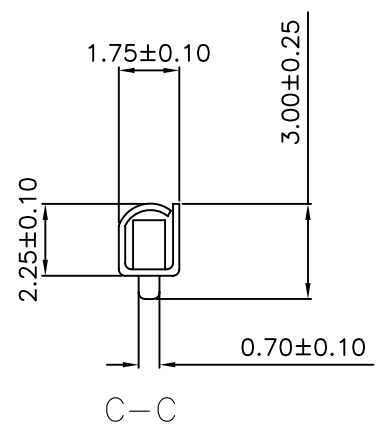
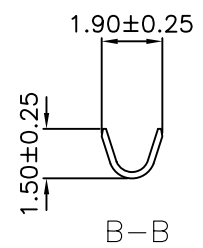
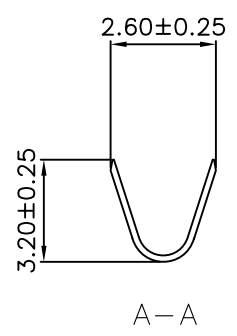
- . Part NO: SCT2501TC
- . Thickness: 0.20mm
- . Wire Range: AWG#22-#28
- . Material: Phos. Bronze
- . Hardness: H
- . Reel Q' ty: 8000pcs



					OPERATION	DRAW	CHENA	05/12/27	SCALE		 森康达电子有限公司 SCONDAR ELECTRONIC LIMITED	
					~ 10 ±0.15	DESIGN			UNIT	mm		
					20 ~ 30 ±0.30	CHECK	MICKY	05/12/28	SIZE	A4	PART NO.	SCT2501TC
0	05/12/27				30 ~ ±0.50	APPROVE	HELLEN	05/12/28	SHEET	1/1	TITLE:	XH2.5 TERMINAL
REV	DATE	MODIFICATION DESCRIPTION		CHANGE	APPROVE				PROJ.	◆	DRAWING NO.	SCT2501

1 2 3 4 5 6 7 8 9 10