

1 2 3 4 5 6 7 8 9 10

A
B
C
D
E
F
G

A
B
C
D
E
F
G

SPECIFICATIONS

Voltage Rating: 100V AC/DC
 Current Rating: 2A AC/DC
 Withstanding Voltage: 800V AC/minute
 Insulation Resistance: 1,000MΩ min.
 Temperature Range: -25° C - +85° C
 Contact Resistance: 20mΩ max

WAFER

Part No: SCT2001WV-S-XXP
 Poles: 2-16
 Material: Nylon 9T, UL94V-0
 Pin: Brass, Tin plated

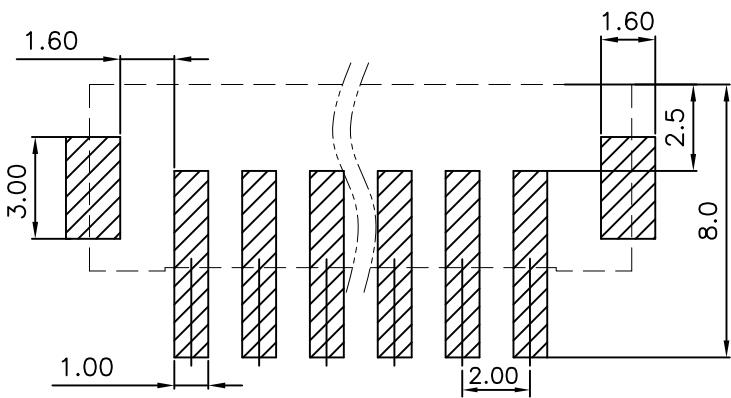
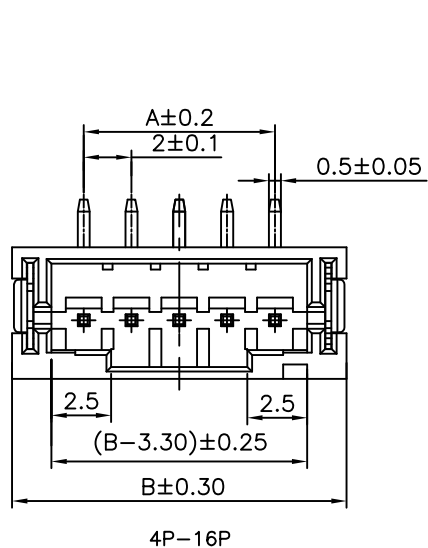

PCB LAYOUT

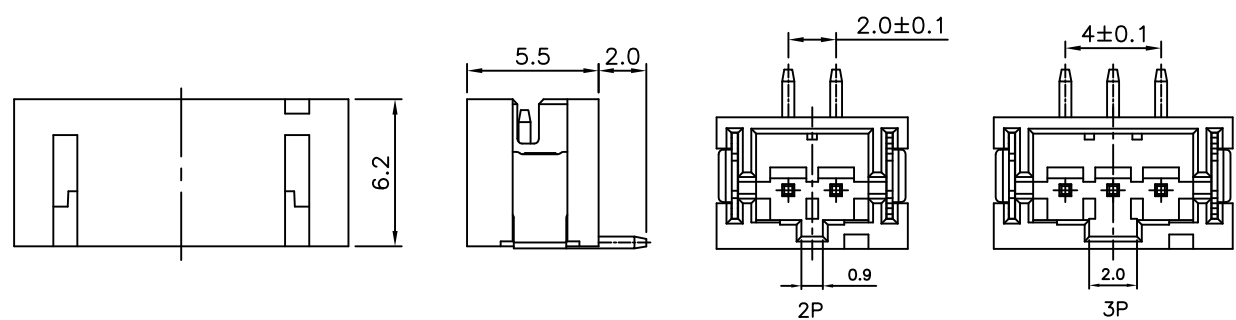

PART NO.	Dimensions	
	A	B
SCT2001WV-S-02P	2.00	8.00
SCT2001WV-S-03P	4.00	10.00
SCT2001WV-S-04P	6.00	12.00
SCT2001WV-S-05P	8.00	14.00
SCT2001WV-S-06P	10.00	16.00
SCT2001WV-S-07P	12.00	18.00
SCT2001WV-S-08P	14.00	20.00
SCT2001WV-S-09P	16.00	22.00
SCT2001WV-S-10P	18.00	24.00
SCT2001WV-S-11P	20.00	26.00
SCT2001WV-S-12P	22.00	28.00
SCT2001WV-S-13P	24.00	30.00
SCT2001WV-S-14P	26.00	32.00
SCT2001WV-S-15P	28.00	34.00
SCT2001WV-S-16P	30.00	36.00

					OPERATION	DRAW	YANG	2016.04.14	SCALE	
					~ 10 ±0.15	DESIGN			UNIT	mm
					20 ~ 30 ±0.30				SIZE	A4
					30 ~ ±0.50		CHECK	MICKY	2016.04.14	SHEET
0	05/12/27	NEW			Angle ± 2'	APPROVE	ALLEN	2016.04.14	PROJ.	⊕ ⊖
REV	DATE	MODIFICATION DESCRIPTION	CHANGE	APPROVE	DIM TOL				TITLE:	PH2.0 180C SMT WAFER

SCONDAR 森康达电子有限公司
 SCONDAR ELECTRONIC LIMITED

PART NO. SCT2001WV-S-XXP
 TITLE: PH2.0 180C SMT WAFER
 DRAWING NO. SCT2001WV-S-XXP

1 2 3 4 5 6 7 8 9 10