

1 2 3 4 5 6 7 8 9 10

A
B
C
D
E
F
G

A
B
C
D
E
F
G

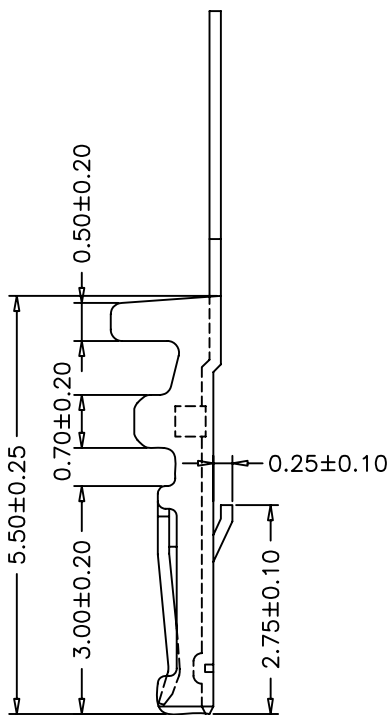
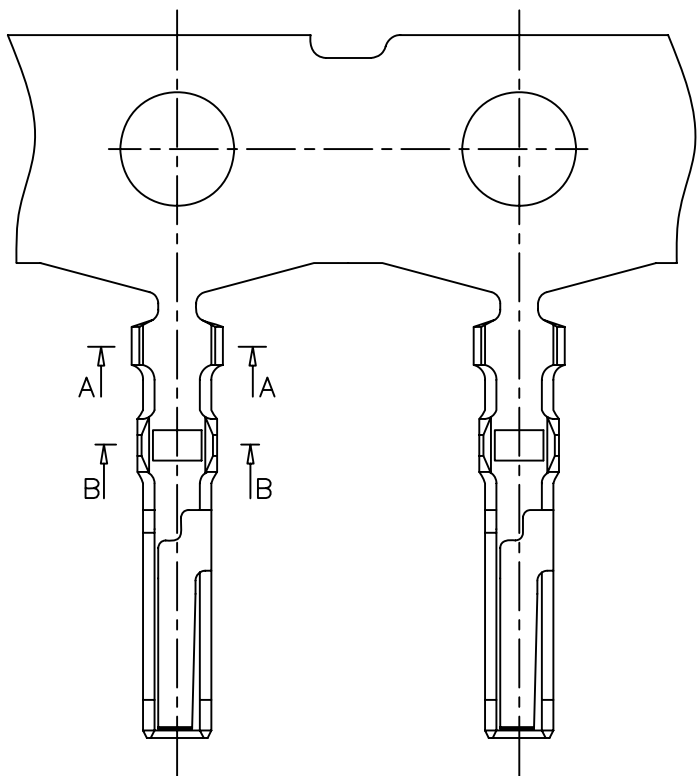

SPECIFICATIONS

Voltage rating: 125V AC, DC
 Current rating: 1A, AC, DC (AWG#28)
 Withstanding voltage: 500V AC/minute
 Insulation resistance: 100M Ω min
 Temperature range: -25°C - +85°C
 Contact resistance: 20mΩ max

TERMINAL

Part No. :SCT1254TPG
 Thickness:0.15mm
 Material:Phosphor. Bronze, Gold plated
 Wire Range:AWG#28-#32
 Reel Q' ty:15,000pcs

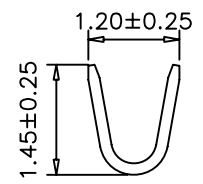
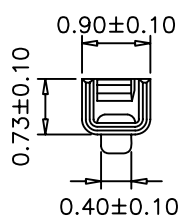

A-A

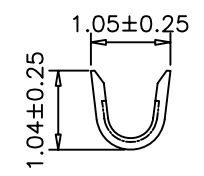

B-B

| | | | | | | | | | | | | |
|-----|----------|--------------------------|--------|---------|---------------|---------|--------|------------|-------|-----|--|--------------------------|
| | | | | | OPERATION | DRAW | JUDY | 2007.05.12 | SCALE | |  森康达电子有限公司 SCONDAR ELECTRONIC LIMITED | |
| | | | | | ~ 10 ±0.15 | DESIGN | | | UNIT | mm | | |
| | | | | | 20 ~ 30 ±0.30 | CHECK | MICKY | 2007.05.12 | SIZE | A4 | PART NO. | SCT1254TPG |
| 0 | 05/12/27 | | | | 30 ~ ±0.50 | APPROVE | HELLEN | 2007.05.12 | SHEET | 1/1 | TITLE: | Molex51146 1.25 Terminal |
| REV | DATE | MODIFICATION DESCRIPTION | CHANGE | APPROVE | Angle DIM | | | | PROJ. | ☯ | DRAWING NO. | SCT1254 |

1 2 3 4 5 6 7 8 9 10