

1 2 3 4 5 6 7 8 9 10

A
B
C
D
E
F
G

A
B
C
D
E
F
G

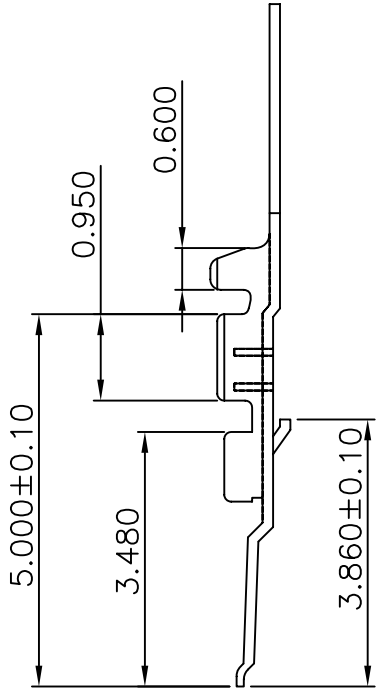
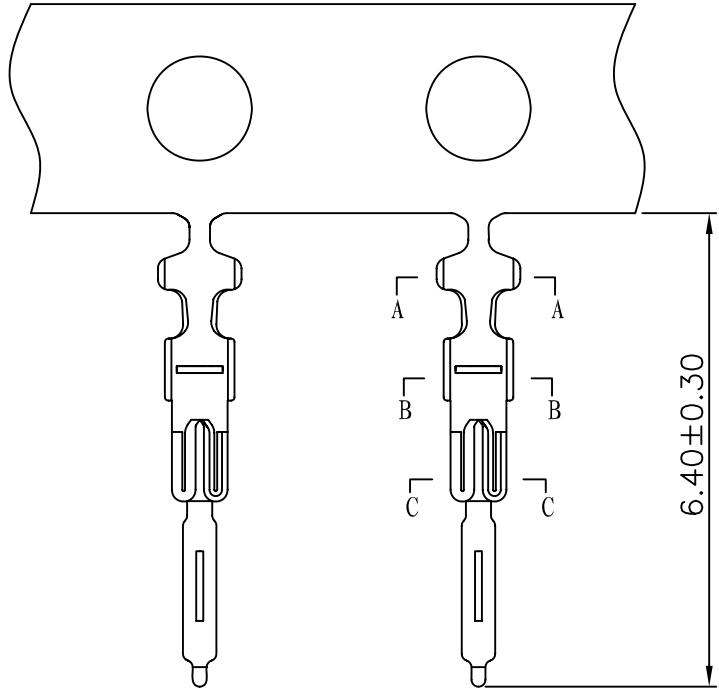

SPECIFICATIONS

Voltage rating: 200V AC, DC
 Current rating: 0.5A, AC, DC (AWG#30)
 Withstanding Voltage: 500V AC/minute
 Insulation resistance: 100MΩ min
 Temperature range: -40°C - +80°C
 Contact resistance: 20mΩ

TERMINAL

Part NO: SCT1004T/1005T/1007T
 Thickness: 0.15mm
 Wire Range: AWG#30-#32 (OD: 0.6mm)
 Material: Phos. Bronze
 Hardness: H
 Reel Q' ty: 20,000PCS

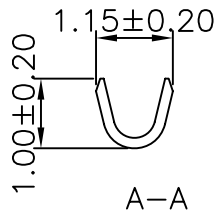

A-A

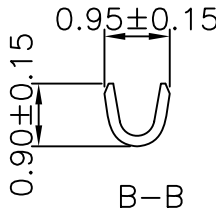

B-B

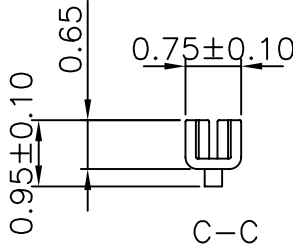

C-C

						OPERATION	DRAW	Judy.Huang	2006/05/02	SCALE		 森康达电子有限公司 SCONDAR ELECTRONIC LIMITED	
						~ 10 ±0.15	DESIGN			UNIT	mm		
						20 ~ 30 ±0.30	CHECK	Micky.Liu	2006/05/02	SIZE	A4	PART NO.	SCT1004T/1005T/1007T
						30 ~ ±0.50	APPROVE	Hellen.Li	2006/05/02	SHEET	1/1	TITLE:	TERMINAL
REV	DATE	MODIFICATION DESCRIPTION		CHANGE	APPROVE	Angle DIM				PROJ.	⊕	DRAWING NO.	SCT1004/1005/1007

1 2 3 4 5 6 7 8 9 10